

# PENNO<sup>®</sup>

## PRESSWOOD PALLET

Model No. PL-1111-87-S2



Quality Control



ISPM 15



Recycle



Cost Saving



**PENNO PACK-TECH CO.,LTD**

No.4 Yangcheng Rd,Fengdu Industrial Zone,Pingyao Town,  
Yuhang District, Hangzhou, China, 311115

Fax: +86 571 8873 4708 | TEL: +86 571 8873 1169

[sales@penno-pallet.com](mailto:sales@penno-pallet.com) | [www.penno-pallet.com](http://www.penno-pallet.com)



Side View

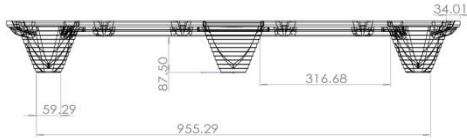

End View

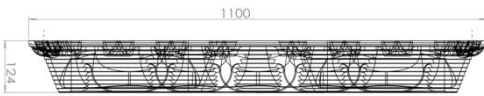

Top View

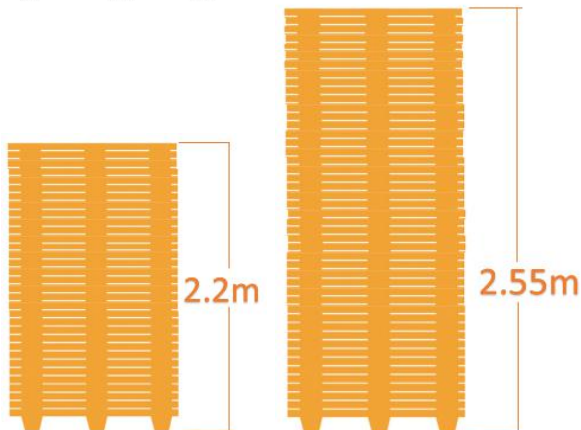
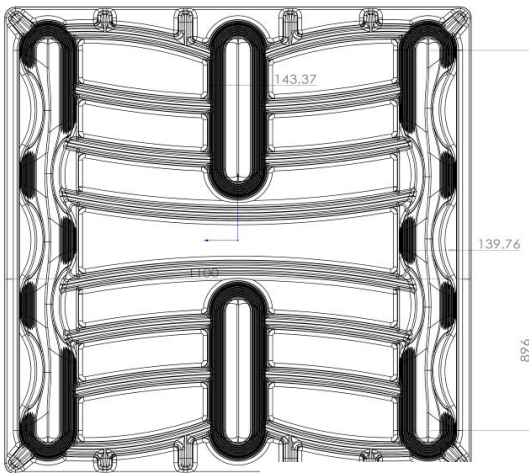

56 pallets

64 pallets

Specification

Model No.	PL-1111-87-S2
Dimension (MM)	1100*1100*125
Weight (KG)	17.5 ± 1.0kg
Forklift Entry	Two-way
Loading Capacity*	1500 KGS (Dynamic)
	4500 KGS (Static)
Qty / Container	500 PCS / 20'GP
	1260 PCS / 40'HQ

### Nestable

Saves your 70% valuable storage space and 50% transportation cost

### Competitive Price

Almost half price for a new export pallet. An ideal alternative to conventional wooden pallets and expensive plastic pallets

### ISPM15 Compliance - Export Approved

The manufacturing process of compress wood pallet takes place under high temperatures and pressure which exterminates bugs, infestation and eliminates the need for costly fumigation or heat treatment prior to export.

### Safety Operation

Rounded corners and No-nail's or screw's design to prevent package from damage and help reduce employee injuries.

